

STRAND MOUNTED HARDENED ACCESS POINT

Wireless Plant extension and Hotspot services are just one truck-roll away. A quick and easy connection at any power passing tap or coupler opens new revenue streams.

The SMHAP is a standards compliant Access Point with an integrated DOCSIS cable modem for backhaul. Single and dual high power 350 mW radios with 802.11n 2X2MIMO technology, support TCP throughputs up 100Mbit full duplex.

The SMHAP can be used in both bridged and routed configurations. Hotspot, Point to Point, Point to Multi-Point and Mesh applications can all be implemented on this extremely flexible device. All variants of the SMHAP are available Mikrotik, RouterOS installed. This powerful networking platform supports advanced routing protocols such as OSPF and MPLS/VPLS. VLANs can be tunnelled using L2TP or SSTP with BCP support. Per connection queuing along with 7 firewall and bridge filters, enforces equal access for all subscribers according to their service class and allows traffic shaping at the edge.

The SMHAP can be managed via SNMP, HHTP, CLI (SSH or Telnet) and an easy to use Windows based utility. Remote firmware updates are supported. User management can be done with a standard radius server, or third party user management service, or for smaller deployments, the included UserManager package can be used. Many vendors of DOCSIS provisioning software have modules to support user management for the SMHAP as well.

SMHAP



BLOCK DIAGRAM

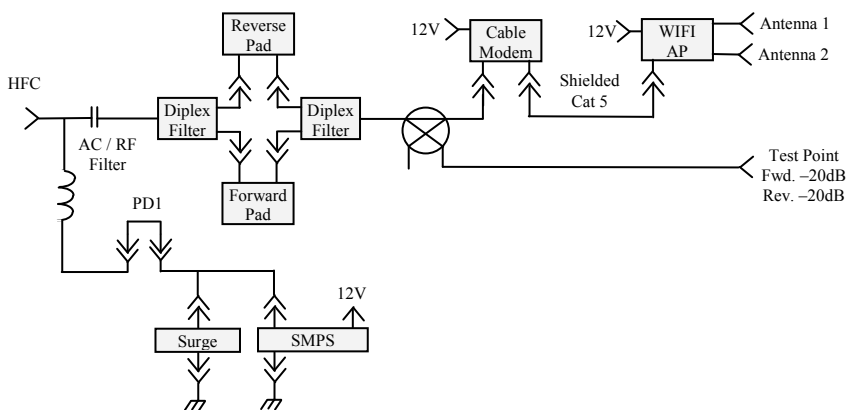

FEATURES

- Die-cast aluminum housing (clamshell design)
- Mounting configurations: wall, pole, vault, mast, or strand
- Dual gaskets provide 15-PSI weather-proof seal
- Temperature cycled, from -40°C to +60°C (-40°F to 140°F)
- Designed to isolate EMI and protect against surges
- Choice of backhaul (DOCSIS 2.0, 3.0 or optical)
- Forward and reverse -20dB test points
- Modem "sweet-spotting" through diplex filters and JXP type attenuators
- Cable plant-powered (40-90 voltage AC)
- Single and dual 802.11a/b/g/n radio options
- Powered by Mikrotik, HP, Ubiquity and additional options
- Omni-directional and directional sector, panel, grid and dish antenna options
- 2 X 2 MIMO two spatial streams
- Supports 16 virtual service communities (SSID)
- Multiple secure management options
- RADIUS interface for authentication, authorization and accounting
- Hotspot, point-to-point/point-to-multipoint operations

SPECIFICATIONS - SMHAP

CABLE MODEM	
Certifications	Cablelabs DOCSIS 1 X/2.0/3.0
Band Plans	DOCSIS (annex B)
Network Configuration and Management	TFTP, SNMP V2, (V3 for DOCSIS 3.0)
RF Input Sensitivity	+15 to -15dBmV
Input Impedence	75 ohm
Privacy	BPI+
Downstream Modulation	64 or 256 QAM
Upstream Mdulation	QPSK and 8,16,32,64, 128 QAM
RADIO	
Tx Power	350mW @6Mbit, 160mW @58MBit
Rx Sensitivity	-94dBm @ 6Mbit, -81 dBm @ 54Mbit
Standards	802.11a/b/g/n (depending on model)
HFC PLATFORM	
Insertion Loss	5 dB ± 1
Return Loss	16dB (max)
Airtight	15 p.s.i.
Temperature Range	-40 to +60 Deg C
EMI Isolation	100 dB (5 to 1000 MHz)
Surge Protection	Gas Discharge Tube
Powering	40-90 Vac (Pseudo Sine)
Power Consumption	18 W (dual radio)
PHYSICAL	
Dimensions	12 X 9 X 6 inches
Weight	8 lbs.

** Note: specifications subject to change without notice

FOR MORE INFORMATION ON OUR WIRELESS, OPTICAL AND RF PRODUCTS
CALL 1-800-465-7046 OR
U.S. Sales Toll free: 877-672-4340